

# ULT 160.1 Product presentation

Complete product portfolio and updates

Benjamin Wirth, Löbau, 01.02.2019

# Summary



**Complete range since January 2019: ACD, ASD, LAS and LRA available**

**Optimized manufacturing with saving effect and better usage**

**Quiet units with high extraction power for up to two working stations**

**5 different standard filters for different applications**

**Fitting accessories**



Absaugen. Filtern. Dranbleiben.

# Features

# Features



## Reduced price by manufacturing optimization

4% price reduction for basic units in 2019 in comparison to 2018

## Improved features

Casters with brakes standard; Carrying handles

## Robust and quiet

Noise < 54 dB(A); proven ULT quality

## New accessory portfolio

Especially chosen accessories for a broad range of applications

## Worldwide usage

Blowers for 100 - 120 V or 230V



Absaugen. Filtern. Dranbleiben.

# Product range

# ULT 160.1 Design



- ★ Intake 2\*DN 50
- ★ Top, removable
- ★ Draw latches
- Casing
- Outlet, adjustable lamelas
- ★ Standard: Castors with brakes  
Optional: feet



Handles ★



Front panel



Backside Interface without SubD9

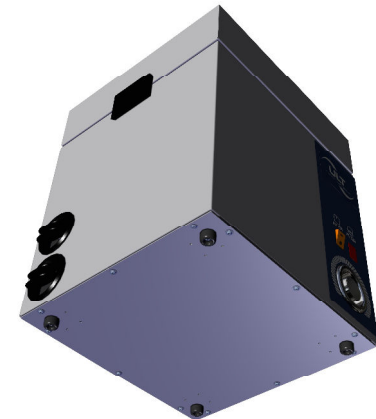

Optional: with feet ★

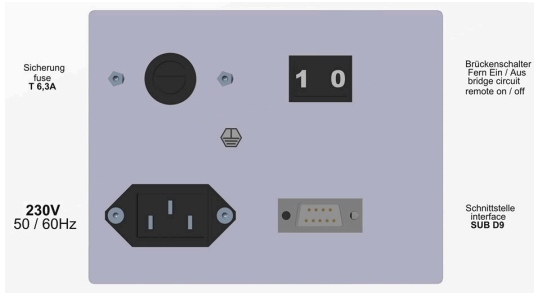

Backside interface with SubD9

★ New/Improved

Absaugen. Filtern. Dranbleiben.

# Measurements

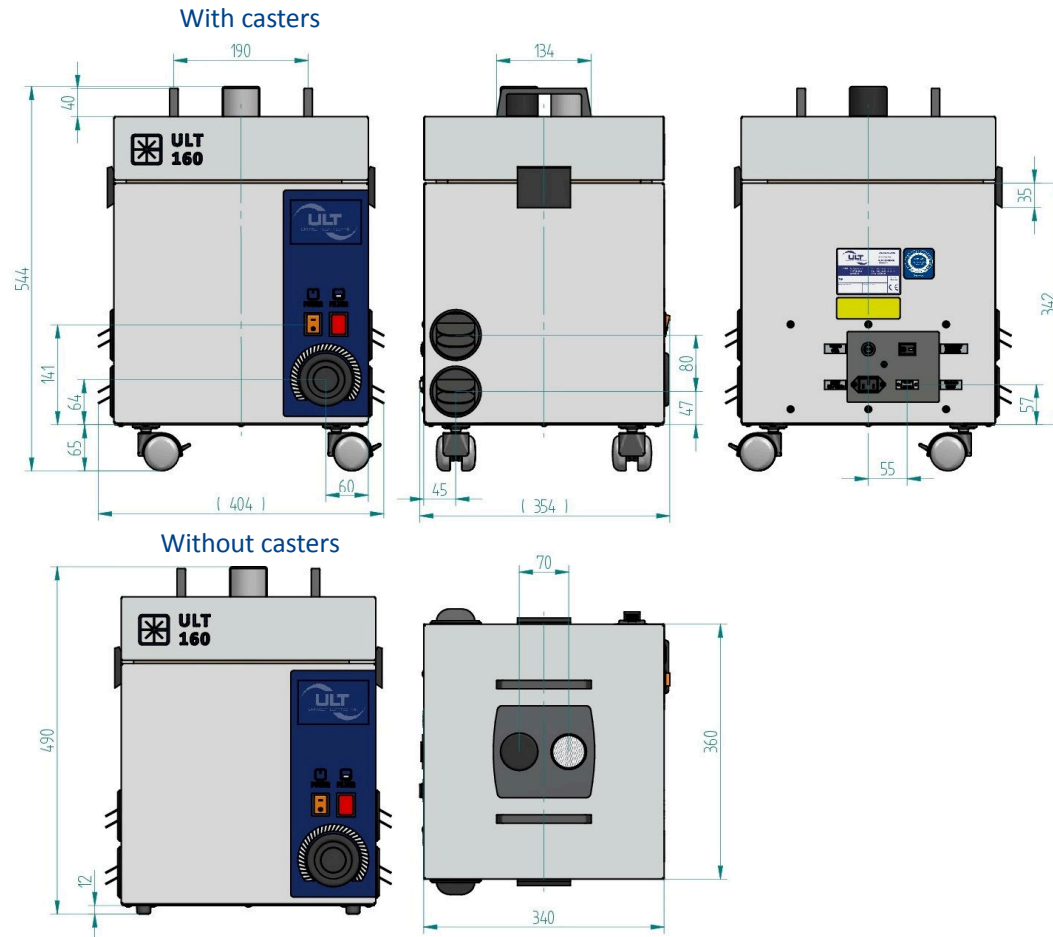

Absaugen. Filtern. Dranbleiben.

# Blower



	<b>MD.11</b>	<b>MD.11b</b>
Volumetric flow max.:	190 m <sup>3</sup> /h	160 m <sup>3</sup> /h
Pressure max.:	3 200 Pa	2 700 Pa
Nominal flow:	80 m <sup>3</sup> /h at 1 900 Pa	80 m <sup>3</sup> /h at 1 400 Pa
Nominal voltage:	1~230 V	1~100 - 120 V
Nominal frequency:	50/60 Hz	50/60 Hz
Nominal current:	1,0 A	2,0 A
Nominal power:	0,15 kW	0,15 kW
Noise level(50% - 100% Power):	49 – 54 dB(A)	49 – 54 dB(A)



# Blower curve MD.11 230V

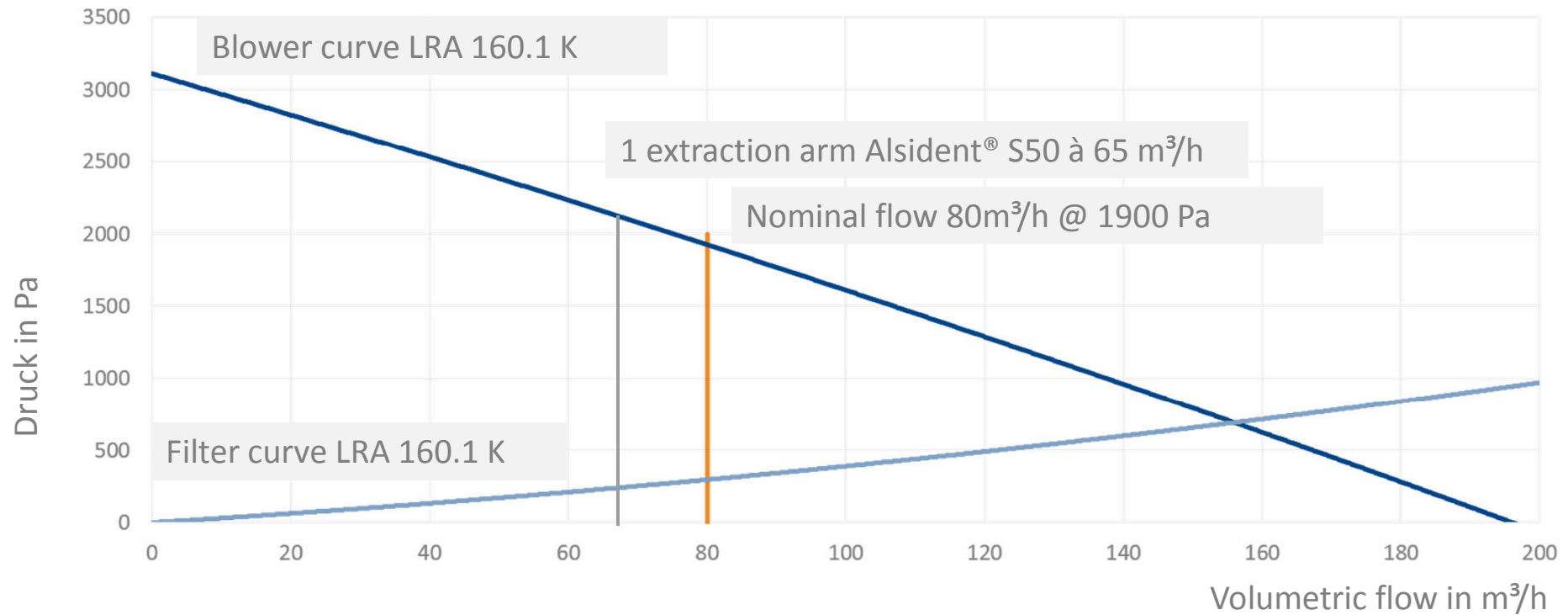

Absaugen. Filtern. Dranbleiben.

# Filter setup

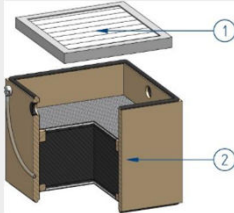
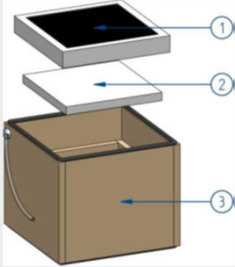
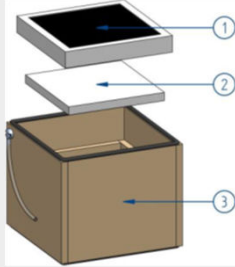
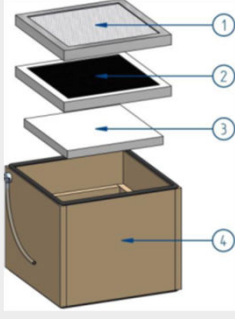
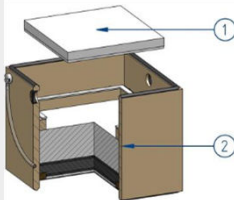
	ACD	ASD	LAS K	LAS SK	LRA K
	Odors, Gas and Vapors	Dust and Smoke	Laser fume	Laser fumes expanded metal	Soldering fumes
Article numbers	ACD 0160.1-MD.11.10.1001 ACD 0160.1-MD.11b.10.1001	ASD 0160.1-MD.11.10.3001 ASD 0160.1-MD.11b.10.3001	LAS 0160.1-MD.11.10.6010 LAS 0160.1-MD.11b.10.6010	LAS 0160.1-MD.11.10.6018 LAS 0160.1-MD.11b.10.6018	LRA 0160.1-MD.11.10.6001 LRA 0160.1-MD.11b.10.6001
Filter setup	 <p><b>Preliminary dust filter</b> - Z-Line Filter G4 <b>Gas filtration</b> - Activated carbon 6 kg</p>	 <p><b>Preliminary dust filter</b> - Z-Line Filter G4 <b>Preliminary dust filter</b> - Filter mat M5 <b>Particulate filter cassette</b> - H13 suspended matter filter</p>	 <p><b>Feinstaubfilter</b> - Panel filter F9 <b>Preliminary dust filter</b> - Filter mat M5 <b>Combined filter cassette</b> - H13 suspended matter filter - Activated carbon filter</p>	 <p><b>Condensation filter</b> - Expanded metal filter <b>Fine dust filter</b> - Panel filter F9 <b>Preliminary dust filter</b> - Filter mat M5 <b>Combined filter cassette</b> - H13 suspended matter filter - Activated carbon filter</p>	 <p><b>Preliminary dust filter</b> - Filter mat M5 und F7 <b>Combined filter cassette</b> - H13 suspended matter filter - Activated carbon filter</p>

# Options

Description	
ULT 0160.1-Opt.03	<p><b>Interface SUB D9</b></p> <p>For remote operation Activation via bridge switch at backside</p> <p>1/2: Operation 4/5/6: Filter – Changer contact 8: 24 VDC Out 9: GND</p>
ULT 0160.1-Opt.04	<p><b>S50 Console for mount of extraction arm</b></p> <p>Mounting of <sup>®</sup> S50 extraction arm Console mounted by ULT with new unit <u>Changed intake</u>: 1 x Alsident<sup>®</sup> flange DN 50</p>

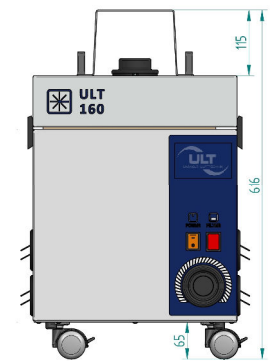
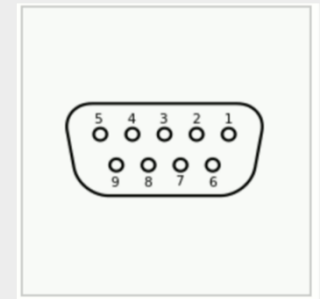

# Accessories

# Extraction hoses



## Extraction system DN50 with sockets, 90° bends and Y-pieces

- Antistatic PU-hoses: DN50
- Sockets/Bends fit unit connectors and Alsident S50
- Preconfectioned hoses with mounted sockets, 90° bends and clamps



Absaugen. Filtern. Dranbleiben.

# Extraction arms

## Alsident Portolio for ULT 160.1:

- S50 antistatic **Flexarms**, black, with extraction tip
  - 600mm; 700mm; 900mm
- S50 antistatic-3-joint arm, black, 945mm:
  - Flat hood, Alu round hood, extraction tip, extraction slit
- Table mount S50(black)



# Facelift comparison

# ULT 160.1 Facelift comparison



## Current setup since serial number 1000

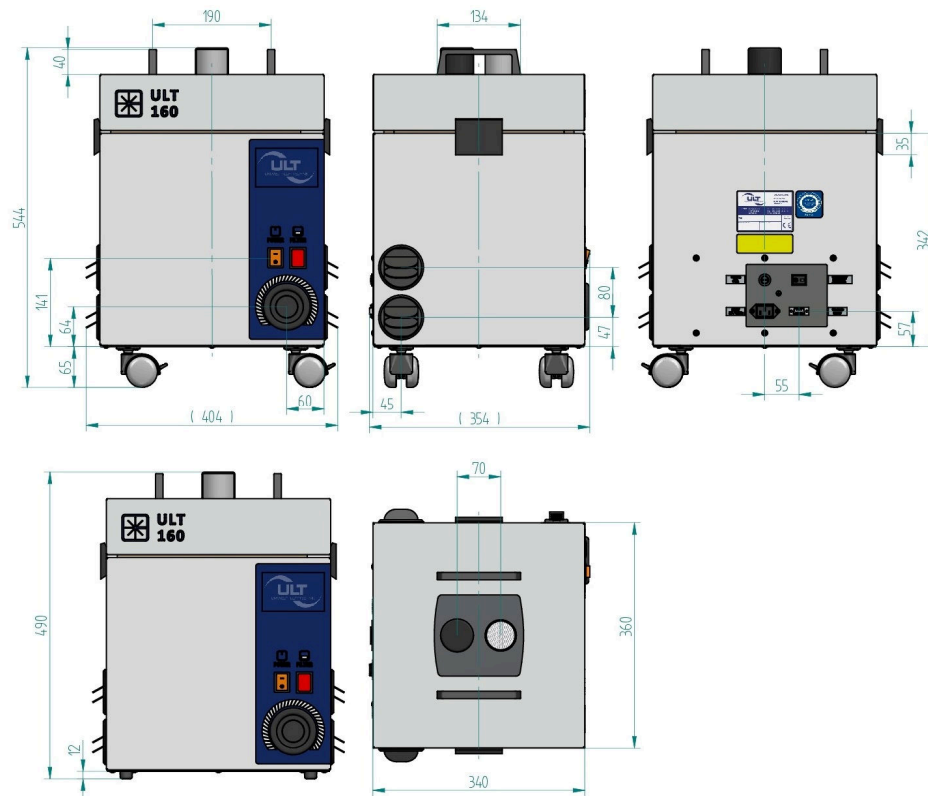

## Setup up to serial number 1000

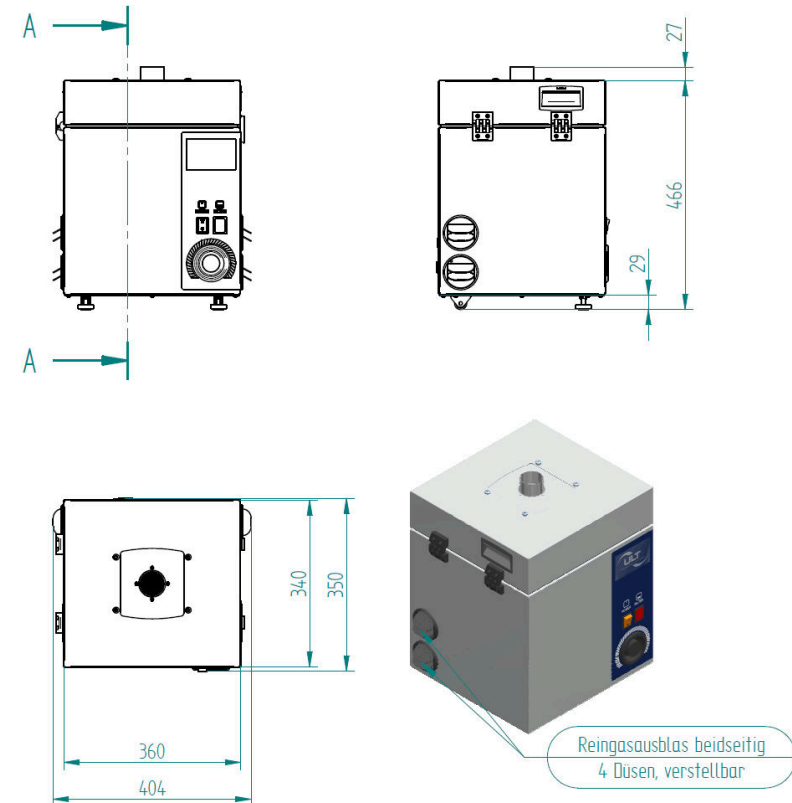

Absaugen. Filtern. Dranbleiben.



# ULT 160.1 Facelift comparison



	Current setup since serial number 1000	Setup up to serial number 1000
Casters	4 big casters standard Very good maneuverability  4 feet optional without extra charge	2 fixed casters + 2 feet Limited maneuverability

Intake	2 welded connectors connectors DN50 Standard	1 take-off DN50 Standard 2 take-off DN50 optional
--------	--	--

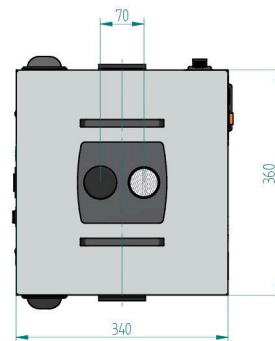
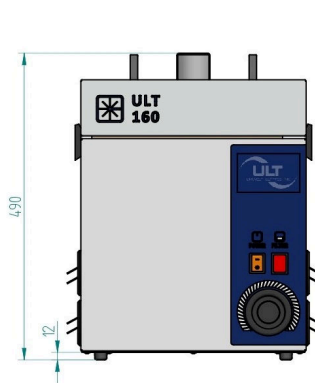

Absaugen. Filtern. Dranbleiben.

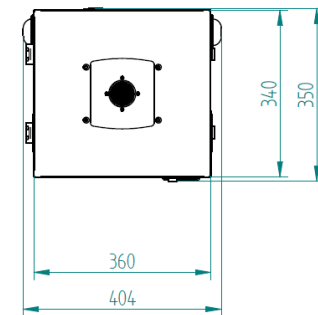
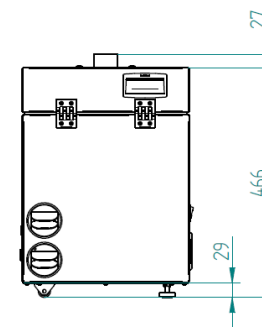

# ULT 160.1 Facelift comparison



	Current setup since serial number 1000	Setup up to serial number 1000
Top	2 big draw latches Top always removable	2 small draw latches + 2 hinges Top tiltable  With mounted Alsident console: 4 small draw latches Top removable
Handles	2 centered handles at top of unit Unit may be carried by handles	2 off-centered shell handles Unit can't be carried by handles



Absaugen. Filtern. Dranbleiben.